



MATHEMATICS APPLICATIONS

Calculator-assumed

ATAR course examination 2017

Marking Key

Marking keys are an explicit statement about what the examining panel expect of candidates when they respond to particular examination items. They help ensure a consistent interpretation of the criteria that guide the awarding of marks.

Section Two: Calculator-assumed

65% (94 Marks)

Question 8

(6 marks)

Ming, a former student of a high school and now a successful business owner, wishes to set up a perpetuity of \$6000 per year, to be paid to a deserving student from her school. The perpetuity is to be paid at the start of the year in one single payment.

- (a) A financial institution has agreed to maintain an account for this perpetuity paying a fixed rate of 5.9% p.a. compounded monthly.

Show that an amount of \$98 974, to the nearest dollar, is required to maintain this perpetuity. (3 marks)

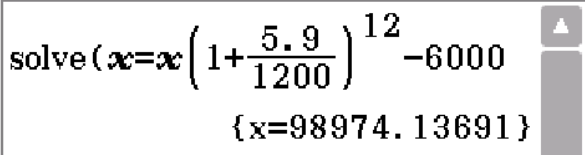
Solution	
	
Specific behaviours	
<ul style="list-style-type: none"> ✓ uses an appropriate method ✓ uses correct monthly interest rate ✓ solves and states solution 	

- (b) Ming allows herself five years to accumulate the required \$98 974 by making regular quarterly payments into an account paying 5.4% p.a. compounded monthly.

Determine the quarterly payment needed to reach the required amount after five years if Ming starts the account with an initial deposit of \$1000. (3 marks)

Solution															
<p style="color: blue; margin: 0;">Compound Interest</p> <table style="width: 100%; border-collapse: collapse;"> <tr> <td style="border: 1px solid black; padding: 2px;">N</td> <td style="border: 1px solid black; padding: 2px;">20</td> </tr> <tr> <td style="border: 1px solid black; padding: 2px;">I%</td> <td style="border: 1px solid black; padding: 2px;">5.4</td> </tr> <tr> <td style="border: 1px solid black; padding: 2px;">PV</td> <td style="border: 1px solid black; padding: 2px;">-1000</td> </tr> <tr> <td style="border: 1px solid black; padding: 2px;">PMT</td> <td style="border: 1px solid black; padding: 2px; background-color: #e0f0ff;">-4283.765562</td> </tr> <tr> <td style="border: 1px solid black; padding: 2px;">FV</td> <td style="border: 1px solid black; padding: 2px;">98974</td> </tr> <tr> <td style="border: 1px solid black; padding: 2px;">P/Y</td> <td style="border: 1px solid black; padding: 2px;">4</td> </tr> <tr> <td style="border: 1px solid black; padding: 2px;">C/Y</td> <td style="border: 1px solid black; padding: 2px;">12</td> </tr> </table> <p style="margin-top: 10px;">Quarterly payment required = \$4283.77</p>		N	20	I%	5.4	PV	-1000	PMT	-4283.765562	FV	98974	P/Y	4	C/Y	12
N	20														
I%	5.4														
PV	-1000														
PMT	-4283.765562														
FV	98974														
P/Y	4														
C/Y	12														
Specific behaviours															
<ul style="list-style-type: none"> ✓ states at least 3 correct entries ✓ states all correct entries ✓ gives the required payment 															

Question 9

(13 marks)

The World Health Organisation produces tables showing Child Growth Standards. The median lengths (cm) for girls at various times during the first five years of life are shown below.

Age (months)	0	3	12	21	27	42	48	60
Median length (cm)	49.1	59.8	74.0	83.7	88.3	99.0	102.7	109.4
Predicted length (cm)	58.2	61.0	69.5	77.9	<i>A</i>	97.7	<i>B</i>	114.7
Residual	-9.1	-1.2	4.5	5.8	4.7	1.3	<i>C</i>	<i>D</i>

- (a) (i) Determine the equation of the least-squares line for predicting the median length from a girl's age. (1 mark)

Solution
$y = 0.942x + 58.159$
Specific behaviours
✓ states correct linear equation

- (ii) Use the equation from (a)(i) to determine the predicted median lengths *A* and *B* in the above table. (2 marks)

Solution
<i>A</i> = 83.6 <i>B</i> = 103.4
Specific behaviours
✓ determines the correct value of <i>A</i> ✓ determines the correct value of <i>B</i>

- (iii) What increase in median length can be expected for each additional year? (1 mark)

Solution
$0.942 \times 12 = 11.30$ cm
Specific behaviours
✓ determines yearly growth rate

- (iv) Given that the correlation coefficient is 0.97, describe the association between age and median length in terms of its direction and strength. (2 marks)

Solution
Positive and strong
Specific behaviours
✓ states direction of association ✓ states strength of association

Question 9 (continued)

- (v) What percentage of the variation in the median length can be explained by the variation in age? (1 mark)

Solution
94.09%
Specific behaviours
✓ correctly calculates percentage

- (b) (i) Determine the residuals *C* and *D* in the table. (2 marks)

Solution
$C = 102.7 - 103.4 = -0.7$
$D = 109.4 - 114.7 = -5.3$
Specific behaviours
✓ correctly determines <i>C</i>
✓ correctly determines <i>D</i>

- (ii) Hence, complete the scattergraph of the residuals against age on the axes below by plotting the last four residual values. (2 marks)

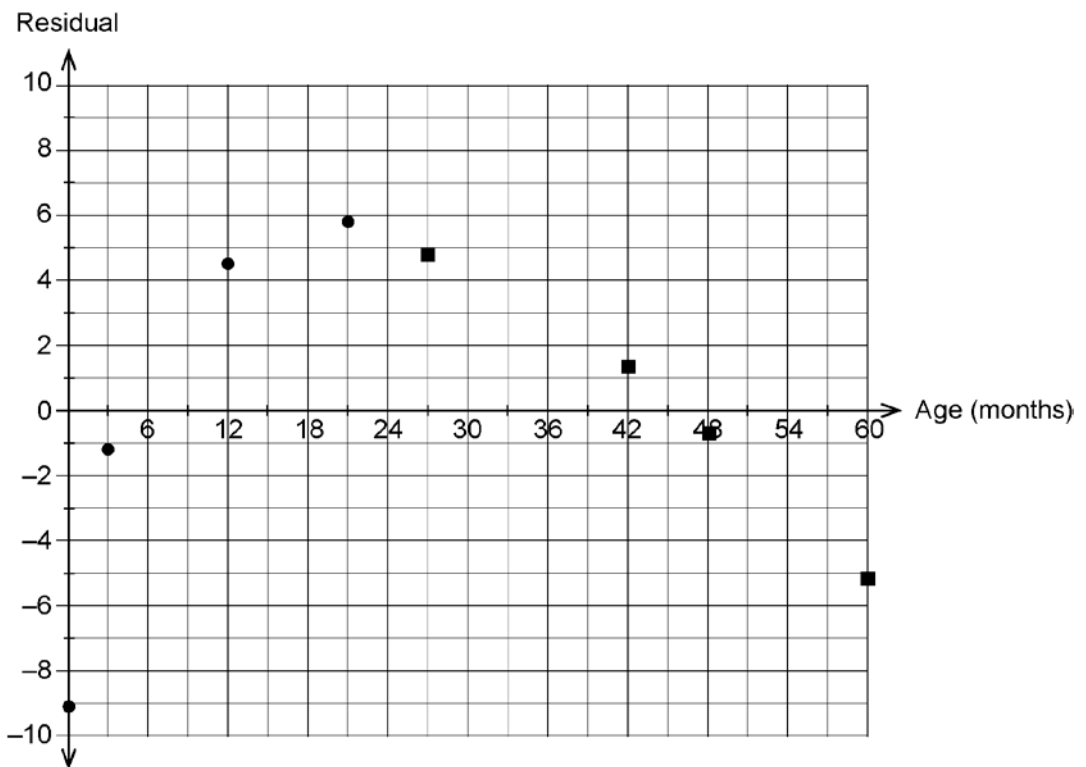

Solution
See graph above (black squares)
Specific behaviours
✓ correctly plots 2 points
✓ correctly plots all 4 points

- (iii) Use the residual plot to assess the appropriateness of fitting a linear model to the data. (2 marks)

Solution
A linear model is not appropriate as there is a pattern in the residuals
Specific behaviours
<ul style="list-style-type: none"> ✓ states that a linear model is not appropriate ✓ gives a valid reason

Question 10

(12 marks)

In a laboratory experiment, the population of a particular bacteria began with 400 present. The population grew at a rate of 35% each week, where P is the number of bacteria and t is the number of weeks from the start of the experiment.

- (a) Four possible equations were produced to model this experiment.

$P = 400(1.35)^t$

$P = 400(0.35)^t$

$P = 540(1.35)^{t-1}$

$P = 540(1.35)^{t+1}$

Circle the correct equation(s). (2 marks)

Solution
See above
Specific behaviours
<ul style="list-style-type: none"> ✓ circles first correct equation ✓ circles second correct equation

- (b) Calculate the population of bacteria after three weeks. (1 mark)

Solution
984
Specific behaviours
✓ calculates the correct population

- (c) During which week did the population of bacteria first reach 1800? (2 marks)

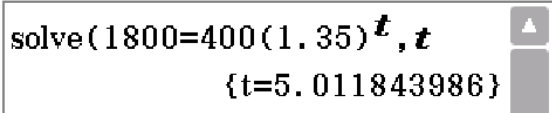
Solution

Therefore during the 6 th week
Specific behaviours
<ul style="list-style-type: none"> ✓ correctly calculates the value of t ✓ correctly states during the sixth week

Question 10 (continued)

- (d) After eight weeks the growth rate slowed to 20% each week. How many weeks in total did it take for the population of bacteria to reach 15 812? (3 marks)

Solution
<div style="border: 1px solid black; padding: 5px; margin-bottom: 10px;"> 400×1.35^8 4412.961508 $\text{solve}(4413(1.2)^t = 15812, t$ $\{t = 6.999799901\}$ </div> <p>Total number of weeks = $8 + 7 = 15$</p>
Specific behaviours
<ul style="list-style-type: none"> ✓ correctly calculates population after 8 weeks ✓ correctly solves equation using new growth rate ✓ correctly states total number of weeks

- (e) What constant weekly growth rate would produce the same change in population from 400 to 15 812 in the same time as found in part (d)? (2 marks)

Solution
<div style="border: 1px solid black; padding: 5px; margin-bottom: 10px;"> $\text{solve}(400(R)^{15} = 15812, R$ $\{R = 1.277796775\}$ </div> <p>$R \approx 1.28$. Therefore new constant growth rate is 28%</p>
Specific behaviours
<ul style="list-style-type: none"> ✓ correctly solves for R ✓ correctly states the new growth rate

- (f) Once the bacteria population reached 15 812 it began to die out at a rate of 250 each day. Approximately how many weeks did it take for the bacteria to die out completely? (2 marks)

Solution
<div style="border: 1px solid black; padding: 5px; margin-bottom: 10px;"> 250×7 1750 $\text{solve}(15812 - 1750T = 0, T$ $\{T = 9.035428571\}$ </div> <p>Time taken is approximately 9 weeks</p>
Specific behaviours
<ul style="list-style-type: none"> ✓ correctly multiplies 250 by 7 ✓ correctly solves equation and states approximate time

Question 11

(11 marks)

The following table, consisting of 11 activities, contains information for a project in a small manufacturing company.

Activity	Immediate Predecessors	Time (hours)
A	–	4
B	–	5
C	A	14
D	A	7
E	–	7
F	–	5
G	B, C	7
H	D	6
J	E, F	9
K	H, J	10
L	G, K	6

(a) Complete the project network below.

(3 marks)

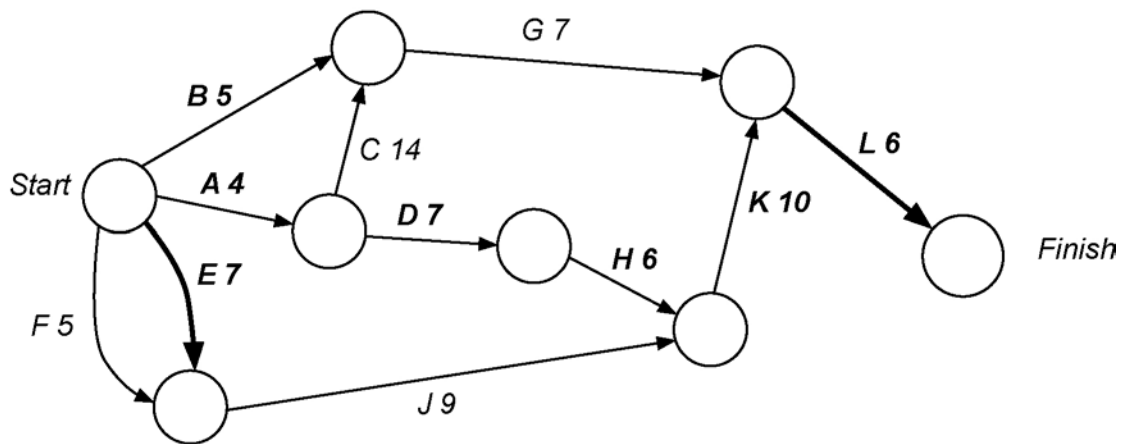

Solution
See above graph
Specific behaviours
<ul style="list-style-type: none"> ✓ correctly draws activities E and L ✓ correctly labels at least 3 edges ✓ correctly labels all edges

(b) State the critical path and the minimum completion time for this network.

(2 marks)

Solution
ADHKL
Minimum completion time is 33 hours
Specific behaviours
<ul style="list-style-type: none"> ✓ states correct path ✓ states correct completion time

Question 11 (continued)

- (c) Determine the float time, earliest starting time, and latest starting time for Activity G. (3 marks)

Solution
Float time = 2 hours Earliest starting time = 18 hours Latest starting time = 20 hours
Specific behaviours
<ul style="list-style-type: none"> ✓ correctly determines the float time ✓ correctly determines the earliest starting time ✓ correctly determines the latest starting time

- (d) Due to some unforeseen problems with Activities G and J, **one** of these activities will require an extra three hours to complete. Which of the activities should be chosen for the completion time to be at a minimum? Justify your answer. (3 marks)

Solution
If G is increased by 3 hours, new completion time is 34 hours (ACGL) If J is increased by 3 hours, new completion time is 35 hours (EJKL)
Therefore choose G to ensure minimum completion time is the smallest
Specific behaviours
<ul style="list-style-type: none"> ✓ correctly determines new completion time for increase in G ✓ correctly determines new completion time for increase in J ✓ correctly concludes that G is the choice

Question 12

(8 marks)

The Bureau of Meteorology recorded data taken from several weather stations. The scatterplot below shows the height, h (m), of each weather station above sea level and the mean minimum temperature, t ($^{\circ}\text{C}$), recorded at that station for the month of April.

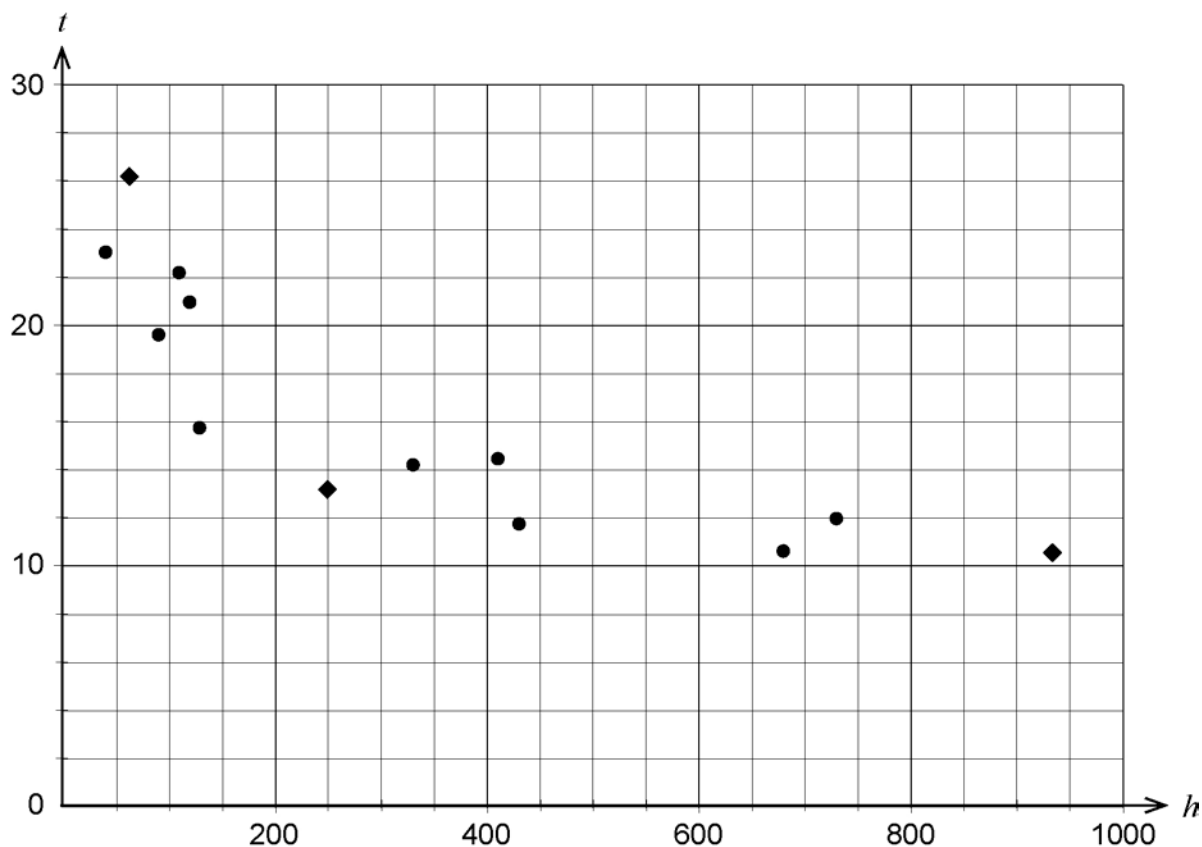

The following table provides this information for three more weather stations for the month of April.

Height of weather station above sea level, h (m)	250	60	930
Mean minimum temperature, t ($^{\circ}\text{C}$)	13.1	26.2	10.6

- (a) Plot this additional information on the scatterplot above. (2 marks)

Solution
See graph above (diamonds)
Specific behaviours
✓ correctly plots 2 points
✓ correctly plots all 3 points

Question 12 (continued)

- (b) The equation of the least-squares line for these data is $t = -0.015h + 21.476$. Draw this line on the scatterplot above. (2 marks)

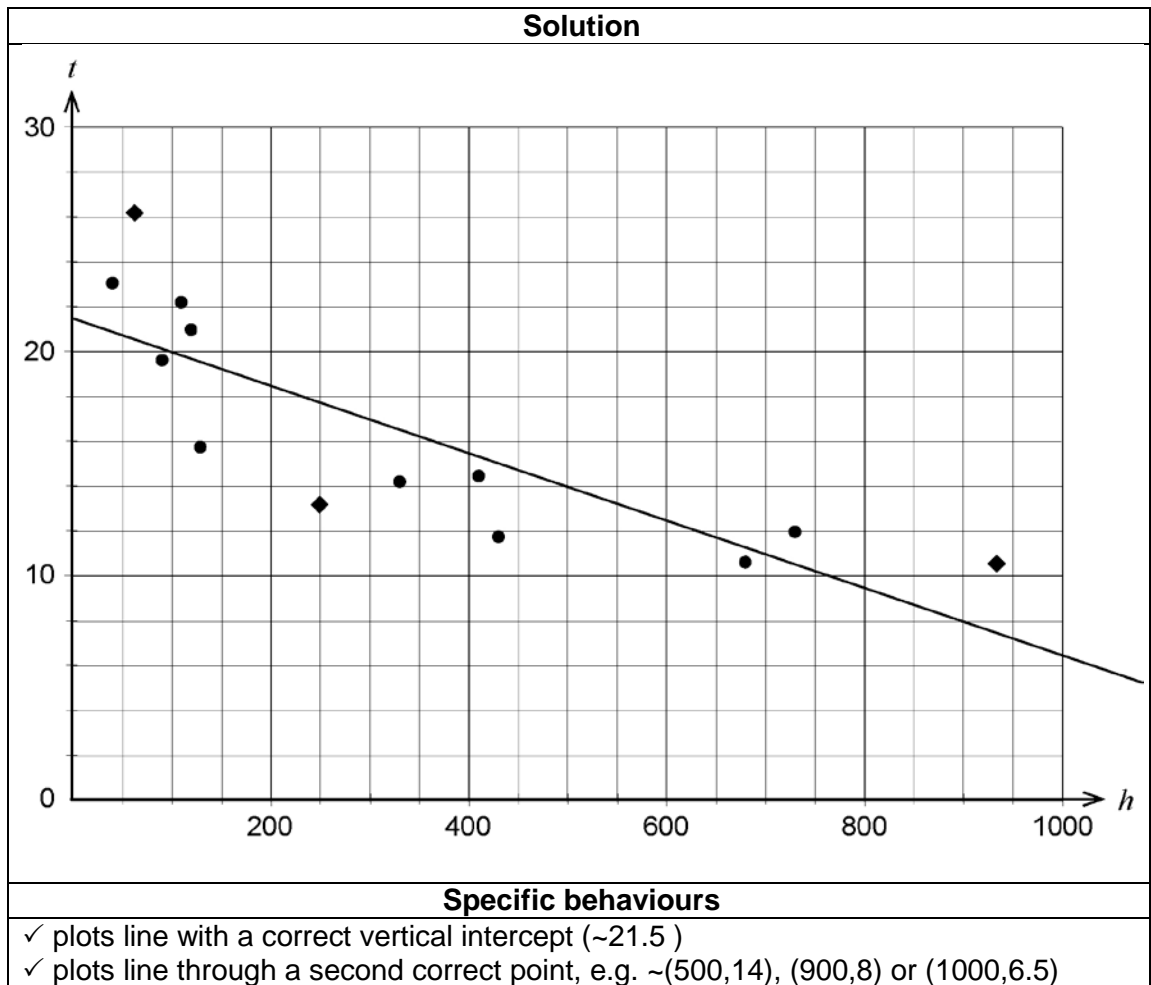

- (c) The correlation coefficient (r) was determined for the collected data. Circle the value of r most likely to be the result from the list below. (1 mark)



- (d) Identify whether the nature of the relationship between the height of a weather station above sea level, h , and the mean minimum temperature, t ($^{\circ}\text{C}$), is linear or non-linear. (1 mark)

Solution
Non-linear
Specific behaviours
✓ correctly identifies non-linear nature of relationship

- (e) A spokesperson for the Bureau of Meteorology summarised the above information from parts (a)–(d), saying ‘It is evident that raising the height of a weather station above sea level causes the mean minimum temperature to drop’. Is this statement correct? Justify your decision. (2 marks)

Solution
Incorrect Cause not established
Specific behaviours
✓ correctly states that that the statement is incorrect ✓ correctly justifies decision

Question 13

(8 marks)

The traffic flow (in hundreds of cars per hour) through a road network (F to H) is shown below.

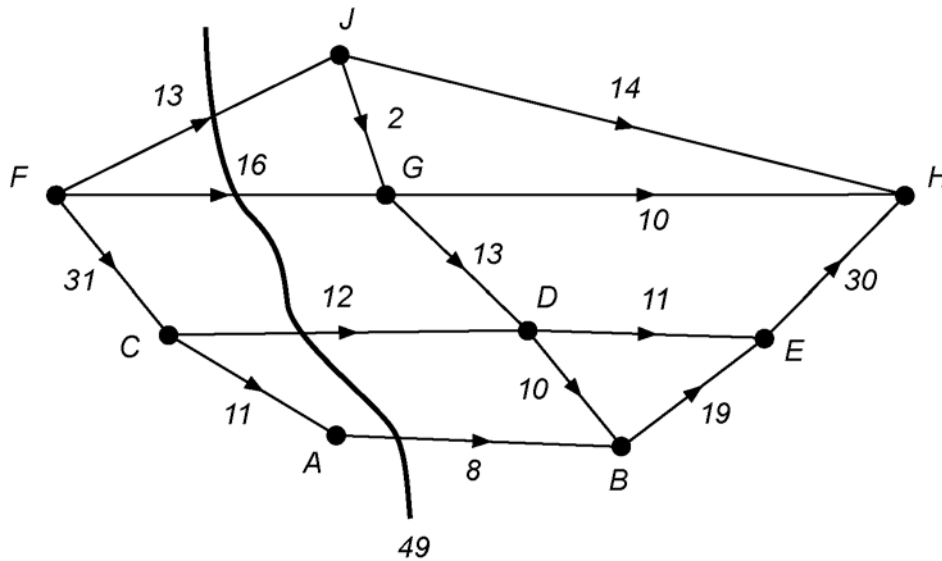

- (a) By listing the different paths and their flow rate, determine the maximum flow through the network. (4 marks)

Solution	
FJH – 13	FJH – 13
FCABEH – 8	FGH – 10
FGH – 10	FGDEH – 6
FGDEH – 6	FCDEH – 5
FCDBEH – 10	FCABEH – 8
FCDEH – 2	FCDBEH – 7
Total is 49.	Total is 49
Maximum flow is 4900 cars per hour	
Specific behaviours	
<ul style="list-style-type: none"> ✓ correctly determines at least two paths with correct flow contribution ✓ correctly determines all paths with correct flow contribution ✓ correctly determines maximum flow ✓ correctly states the maximum flow in cars per hour 	

- (b) Verify the maximum flow obtained in part (a) by showing the minimum cut on the given network. (1 mark)

Solution
See above graph
Specific behaviours
✓ draws correct minimum cut

- (c) (i) If **one** road is to be widened to allow for more traffic, which road should be chosen to increase the maximum flow the most? (1 mark)

Solution	
Either FG or CD or FJ	(AB) alternative pathway
Specific behaviours	
✓ correctly identifies one road	

- (ii) How much more traffic should this road allow to flow and what would be the new maximum flow for the network? (2 marks)

Solution	
By increasing either FG or CD by 3 (300 cars per hour) or increasing AB by 3 (300 cars per hour) the new maximum flow would be 5200 cars per hour.	
Specific behaviours	
✓ correctly states increase on the road	
✓ correctly states new maximum flow	

Question 14

(13 marks)

Andrew takes out a \$14 999 loan to purchase his first car after paying a \$1200 deposit. The car dealer offered the loan at an introductory interest rate of 1.80% p.a. for the first year and then the rate becomes 3.24% p.a. for the remaining time of the loan. Interest is added monthly and Andrew has calculated he can afford to make monthly repayments of \$420.

- (a) (i) Express the loan repayment process for the first year as a recursive formula. (2 marks)

Solution	
$T_{n+1} = \left(1 + \frac{1.80}{1200}\right)T_n - 420, T_0 = 14\ 999$	
Specific behaviours	
✓ states correct recursive rule	
✓ states T_0	

- (ii) How much does Andrew still owe after one year? (1 mark)

Solution	
$T_{12} = 10\ 189.43$	
Therefore, Andrew still owes \$10 189.43	
Specific behaviours	
✓ correctly calculates T_{12}	

Question 14 (continued)

- (b) How much does Andrew owe after two years? (3 marks)

Solution
$T_{n+1} = \left(1 + \frac{3.24}{1200}\right)T_n - 420, T_0 = 10\,189.43$ $T_{12} = 5408.99 \text{ (5409)}$ Therefore, Andrew owes \$5408.99 (\$5409) after two years
Specific behaviours
✓ states correct recursive rule ✓ states T_0 ✓ correctly calculates T_{12}

- (c) How long does it take Andrew to repay the loan? (2 marks)

Solution
Using the recursive rule from part (b), $T_{25} = 52.62$, therefore would take $26 + 12 = 38$ months for Andrew to repay the loan
Specific behaviours
✓ correctly calculates time from second recursive rule ✓ correctly calculates total time to repay loan

- (d) Determine the amount of the final repayment. (2 marks)

Solution
Using the recursive rule from part (b), $T_{26} = -367.23$, therefore the final repayment would be $420 - 367.23 = \$52.77$
Specific behaviours
✓ correctly calculates T_{26} from second recursive rule ✓ correctly calculates final repayment

- (e) Calculate the total cost of the car. (3 marks)

Solution
$\text{Total cost} = (37 \times 420) + 52.77 + 1200 = \$16\,792.77$
Specific behaviours
✓ correctly uses 37 months ✓ correctly adds on final repayment ✓ correctly adds on deposit and gives total cost

Question 15

(15 marks)

(a) The table below shows some time series data where t represents time.

t	1	2	3	4	5	6	7	8
x	14	17	18	24	21	19	16	13

Calculate at $t = 4$

(i) the 3-point moving average. (1 mark)

Solution
3-point moving average = $\frac{18 + 24 + 21}{3} = 21$
Specific behaviours
✓ correctly calculates 3-point moving average

(ii) the 6-point centred moving average. (2 marks)

Solution
6-point centred moving average = $\frac{\frac{14}{2} + 17 + 18 + 24 + 21 + 19 + \frac{16}{2}}{6} = 19$
Specific behaviours
✓ correctly halves first and last values
✓ correctly calculates 6-point centred moving average

(b) A retailer in a shopping centre sells mobile phones. The data of its quarterly sales, together with some calculations, are shown in the table below.

Year	Data number (n)	Quarter	Mobile phone sales	Quarterly mean	Percentage of quarterly mean	Deseasonalised figure (D)
2013	1	March	901	905	99.56	915
	2	June	802		88.62	914
	3	September	A		97.68	900
	4	December	1033		114.14	894
2014	5	March	973	984.5	98.83	988
	6	June	863		C	984
	7	September	964		97.92	981
	8	December	1138		115.59	985
2015	9	March	1049	1065.5	98.45	1065
	10	June	932		87.47	E
	11	September	1049		98.45	1068
	12	December	1232		115.63	1066
2016	13	March	1119	B	97.01	1136
	14	June	1006		87.21	1147
	15	September	1142		99.00	1162
	16	December	1347		116.78	1166

Question 15 (continued)

- (i) Determine the value of A , B and C in the table in part (b) on the previous page. (3 marks)

Solution
$\frac{901+802+A+1033}{4} = 905 \Rightarrow A = 884$
$B = \frac{1119+1006+1142+1347}{4} = 1153.5$
$C = \frac{863}{984.5} \times 100 = 87.66\%$
Specific behaviours
<ul style="list-style-type: none"> ✓ correctly calculates the value of A ✓ correctly calculates the value of B ✓ correctly calculates the value of C

- (ii) Complete the Seasonal Index table below. (1 mark)

Quarter	March	June	September	December
Seasonal Index	0.9846	0.8774	0.9826	1.1554

Solution
See table above
Specific behaviours
✓ correctly calculates seasonal index

- (iii) Determine the value of E in the table in part (b) on the previous page. (2 marks)

Solution
$E = \frac{932}{0.8774} = 1062$
Specific behaviours
<ul style="list-style-type: none"> ✓ uses correct seasonal index ✓ divides 932 by seasonal index

The equation of the least-squares line for deseasonalised figure against data number is $D = 19.37n + 862.4$.

- (iv) The graph below shows the deseasonalised figures. Draw, on the graph, the least-squares line. (2 marks)

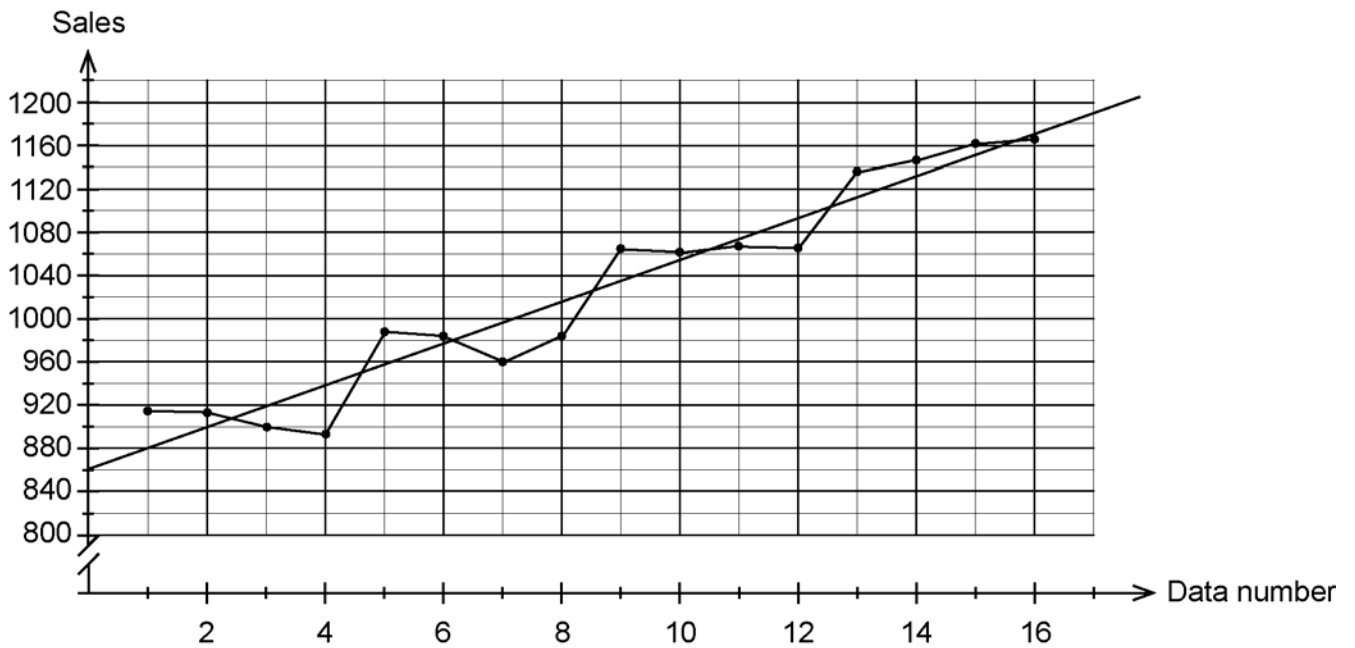

Solution
See graph above
Specific behaviours
<ul style="list-style-type: none"> ✓ shows correct vertical intercept ✓ shows correct slope

- (v) Predict the mobile phone sales for December 2017. (2 marks)

Solution
Prediction = $(19.37 \times 20 + 862.4) \times 1.1554 = 1444$ phones
Specific behaviours
<ul style="list-style-type: none"> ✓ uses correct value of n ✓ multiplies by correct seasonal index

- (vi) Comment on the reliability of your prediction made in part (v). (2 marks)

Solution
Prediction is reliable as it is within one cycle of known data
Specific behaviours
<ul style="list-style-type: none"> ✓ states prediction is reliable ✓ gives valid reason

Question 16

(8 marks)

In a Northern Territory river, the crocodile population is dropping by 7.5% each year. The current population is 200. A scheme is being trialled under which 20 crocodiles are introduced to the river each year.

The population of crocodiles in the river can be modelled by the first-order linear recurrence relation $T_{n+1} = 0.925T_n + b$, $T_1 = 200$, where T_n is the number of crocodiles in the river at the beginning of the n^{th} year.

- (a) (i) Interpret the coefficient 0.925 in the context of the question. (1 mark)

Solution
Only 92.5% of the crocodiles remain in the river each year
Specific behaviours
✓ interprets the coefficient correctly

- (ii) State the value of b . (1 mark)

Solution
$b = 20$
Specific behaviours
✓ states the correct value of b

- (b) Graph the number of crocodiles in the river for every five year period (commencing at $n = 5$), up to the 30th year on the axes below. (2 marks)

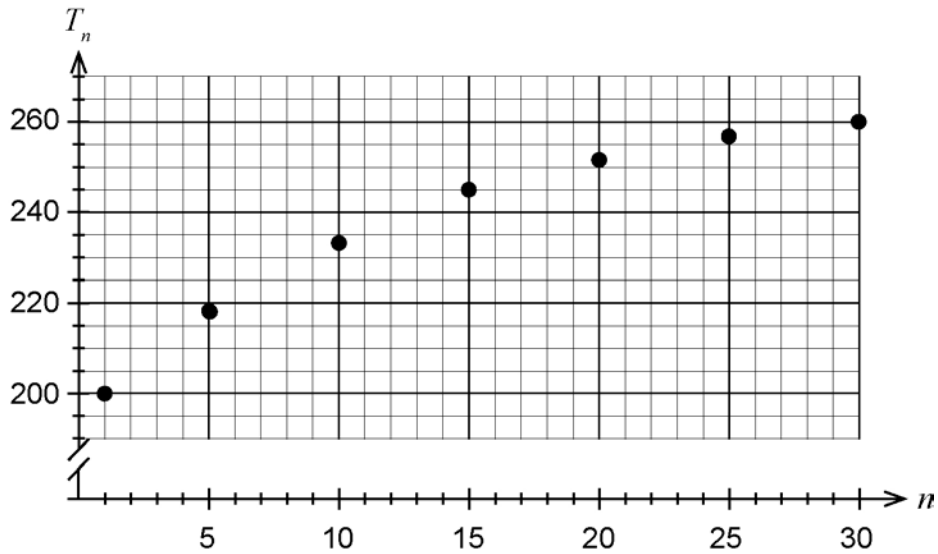

Solution
See above graph
Specific behaviours
✓ correctly plots at least two points
✓ correctly plots all points

- (c) Using your graph, comment on how the population of crocodiles is changing over time. (2 marks)

Solution
Population is increasing
Population is levelling
Specific behaviours
✓ states that population is increasing
✓ describes the change

- (d) To the nearest whole number, what is the long-term effect on the crocodile population? (2 marks)

Solution
$x = 0.925x + 20 \Rightarrow x \approx 267$
The population of crocodiles will settle to approximately 267
Specific behaviours
✓ correctly sets up steady state equation
✓ correctly solves to nearest whole number

ACKNOWLEDGEMENTS

Question 9

Table data source: World Health Organisation. (2006). *Child growth standards: Weight for length/height* [Girls percentiles from birth to 5 years]. Retrieved June, 2017, from www.who.int/childgrowth/standards/chts_wflh_girls_p/en/

This document – apart from any third party copyright material contained in it – may be freely copied, or communicated on an intranet, for non-commercial purposes in educational institutions, provided that it is not changed and that the School Curriculum and Standards Authority is acknowledged as the copyright owner, and that the Authority's moral rights are not infringed.

Copying or communication for any other purpose can be done only within the terms of the *Copyright Act 1968* or with prior written permission of the School Curriculum and Standards Authority. Copying or communication of any third party copyright material can be done only within the terms of the *Copyright Act 1968* or with permission of the copyright owners.

Any content in this document that has been derived from the Australian Curriculum may be used under the terms of the Creative Commons [Attribution 4.0 International \(CC BY\)](https://creativecommons.org/licenses/by/4.0/) licence.

*Published by the School Curriculum and Standards Authority of Western Australia
303 Sevenoaks Street
CANNINGTON WA 6107*